



SN.

Dr. Jekyll & Mr. Hyde[®]

THE EXHAUST

MANUAL : INDIAN[®] | EASYMOUNT | SMARTBOX 2

NEW IN THIS MANUAL:

- FIREGUM
- SERVO MOUNTING



Scout

1

Scout Easymount Smartbox 2

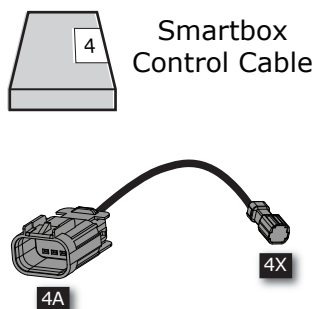
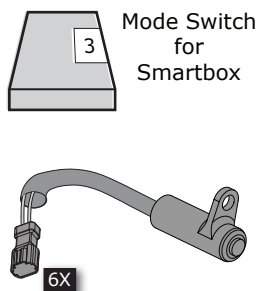
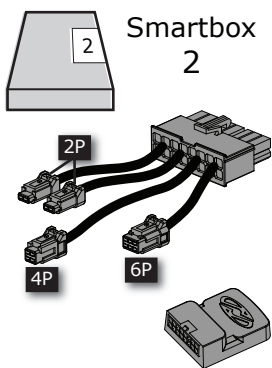

Exhaust/Cable /Servo System

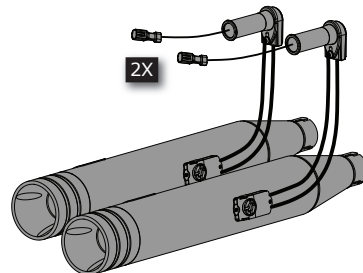

2

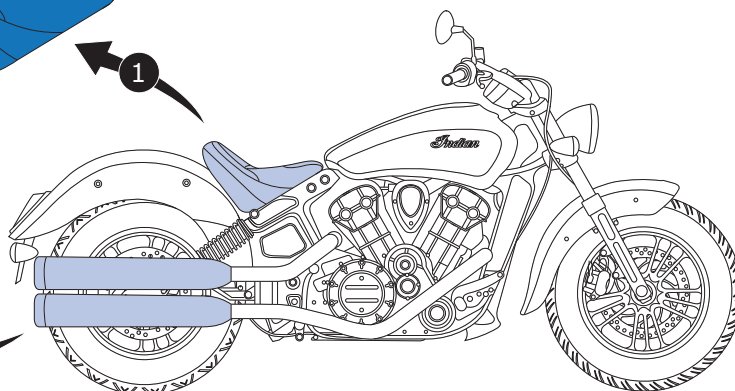
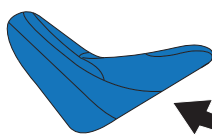
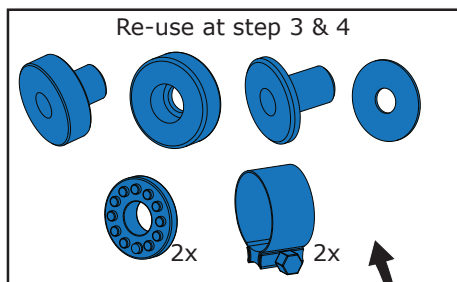

3

Exhaust assembly

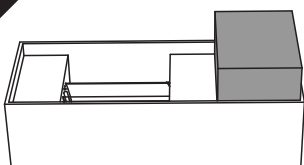

Items required

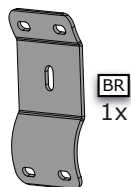

Tighten at step 4 !

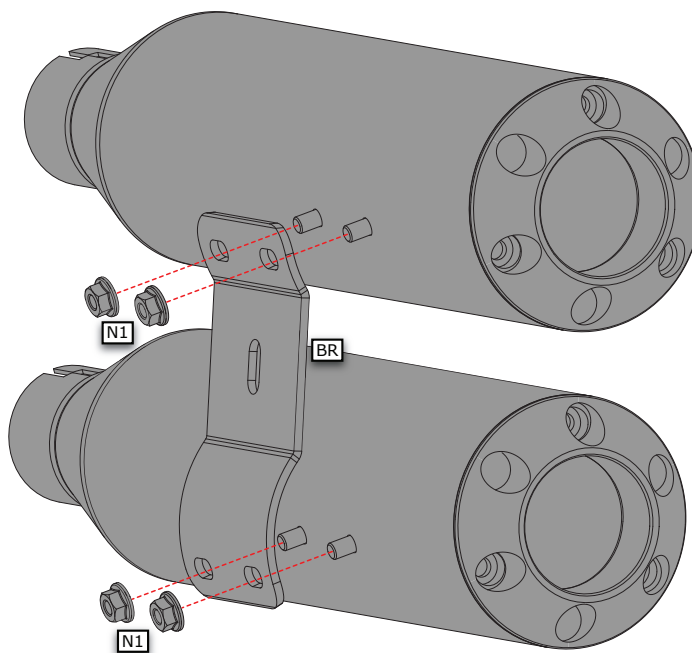
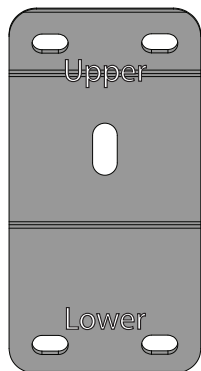

2017 & up models.

4

Exhaust installation on motorcycle

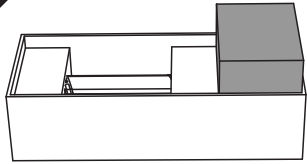

Items required

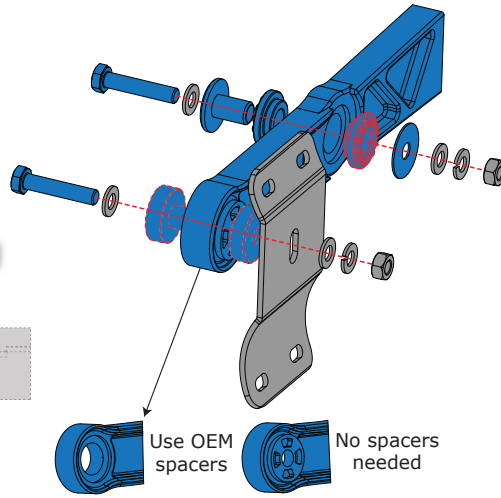
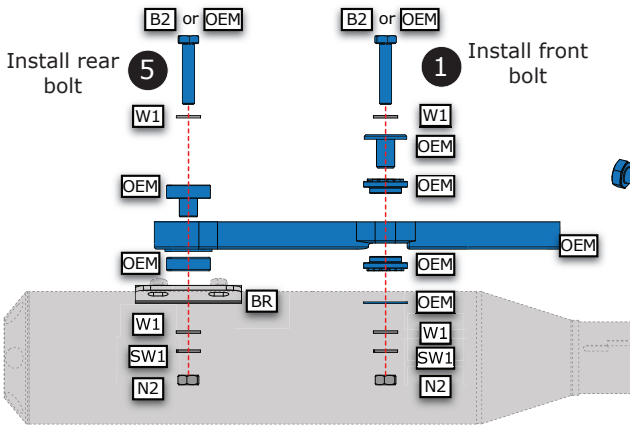
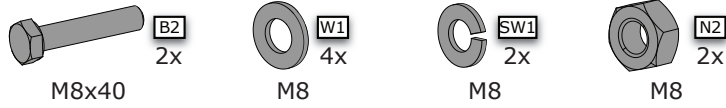

Use OEM spacers
No spacers needed

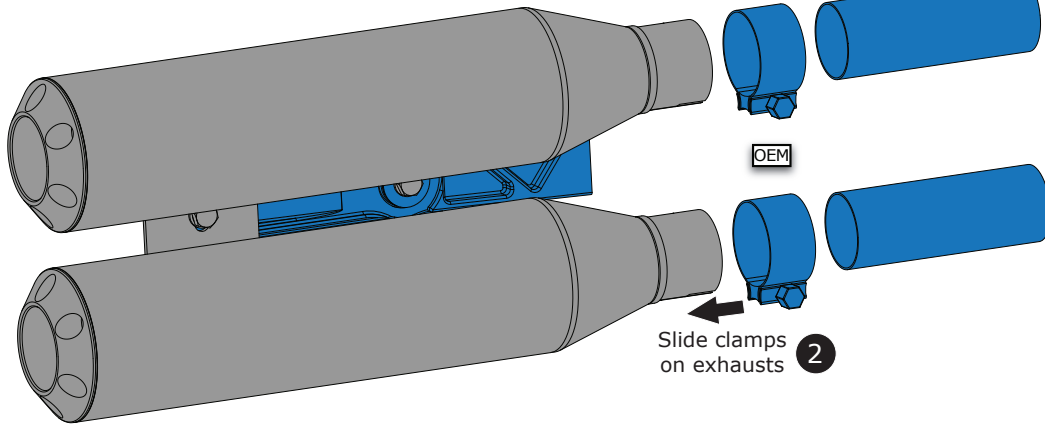

3 FIREGUM

Apply a small amount of firegum into the cutouts of the exhaust and a thin layer on the circumference, as shown below: (ca. 3 grams per exhaust)

Avoid using an excessive amount of firegum, which could cause damage to the dampers

Align exhausts and tighten N1

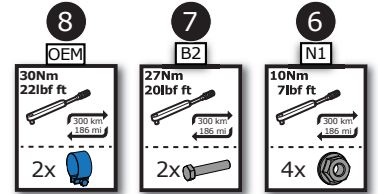

5

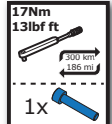
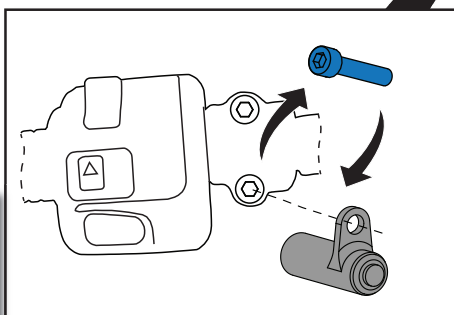
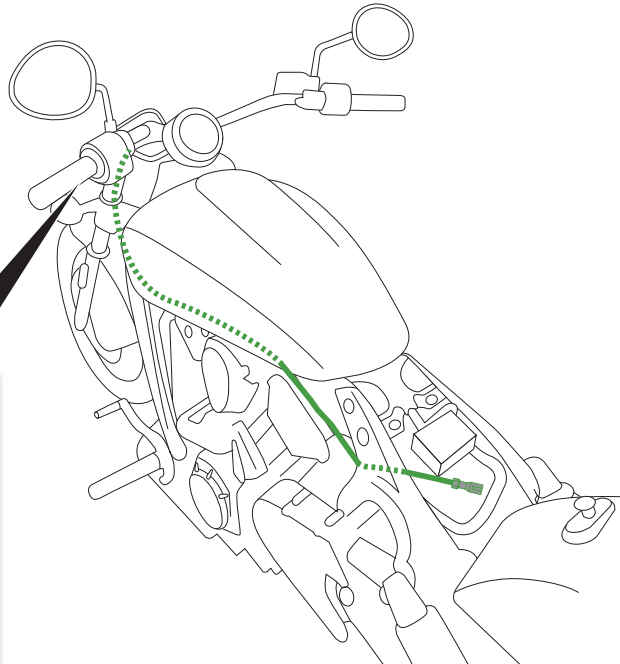
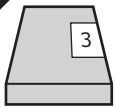

2015 - 2016 models.

4

Exhaust installation on motorcycle

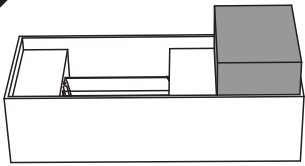

Items required

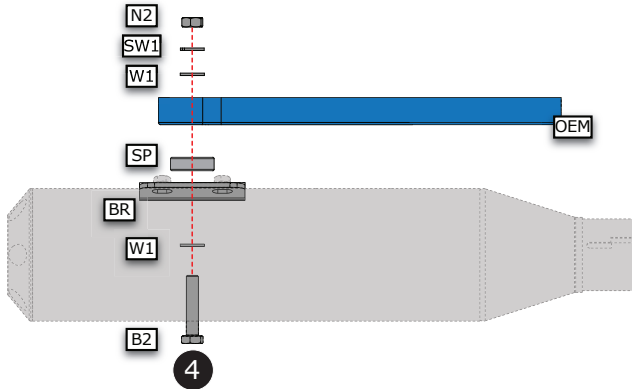
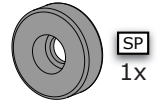
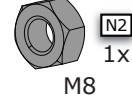
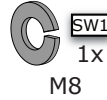
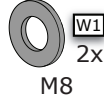
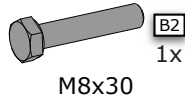

4
Install rear bolt

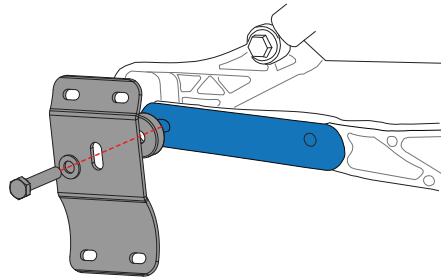

3
Slide exhausts on OEM header

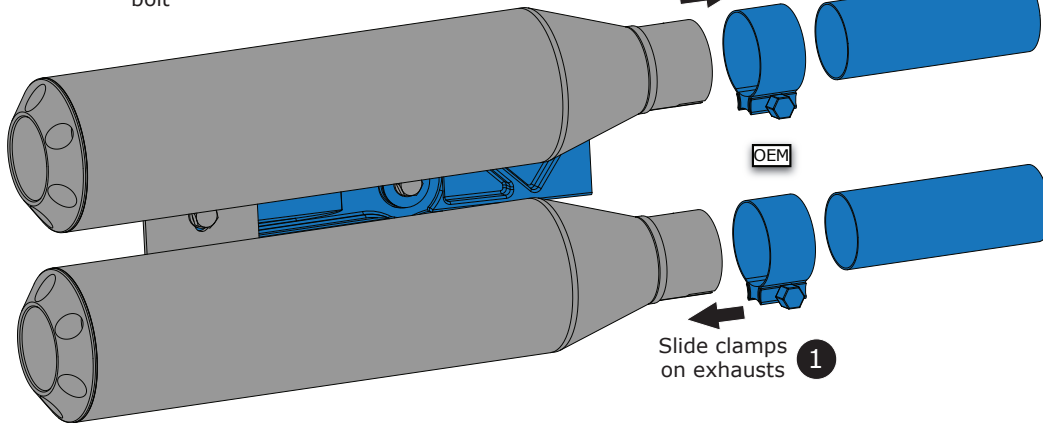

1
Slide clamps on exhausts



2
Apply a small amount of firegum into the cutouts of the exhaust and a thin layer on the circumference, as shown below: (ca. 3 grams per exhaust)

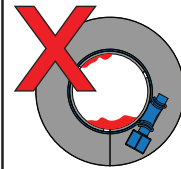
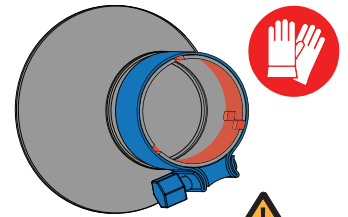

⚠️
Avoid using an excessive amount of firegum, which could cause damage to the dampers

Align exhausts and tighten N1



5

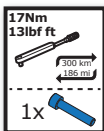
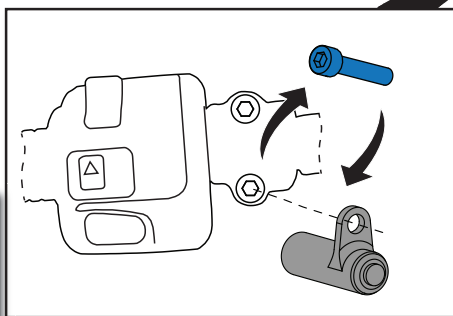
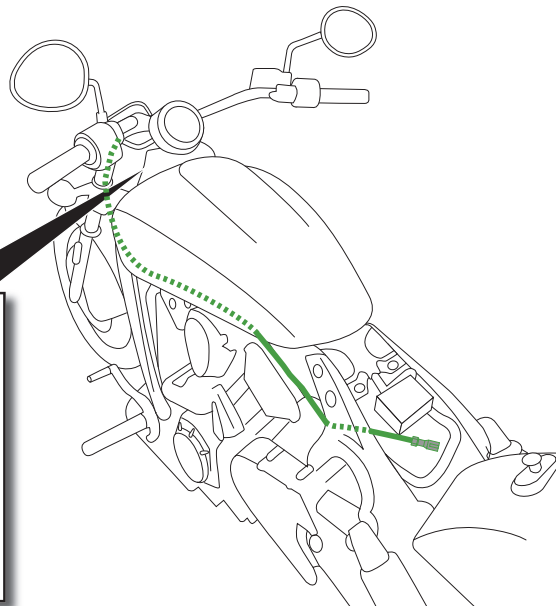
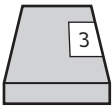

6

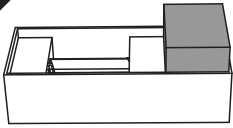

Items required

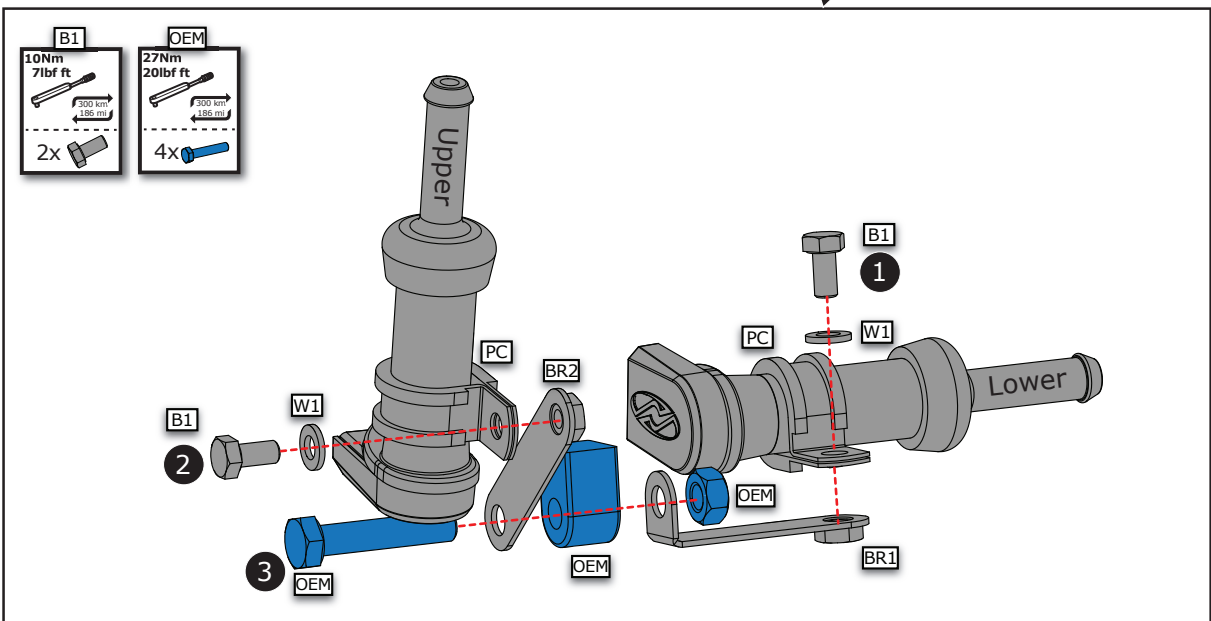
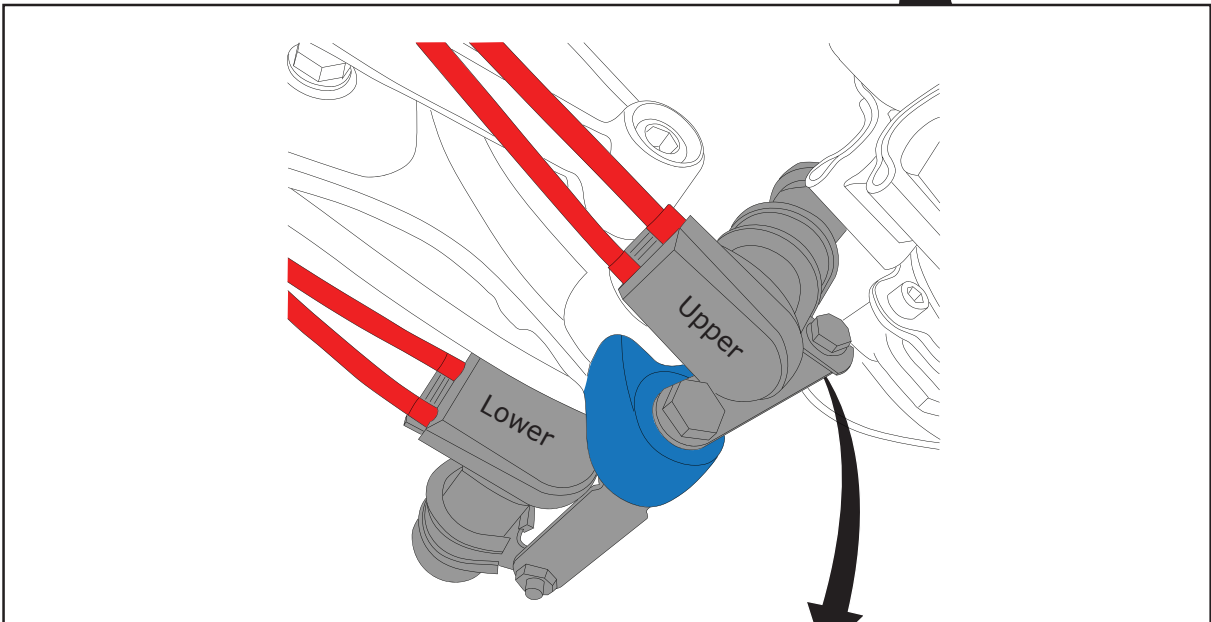
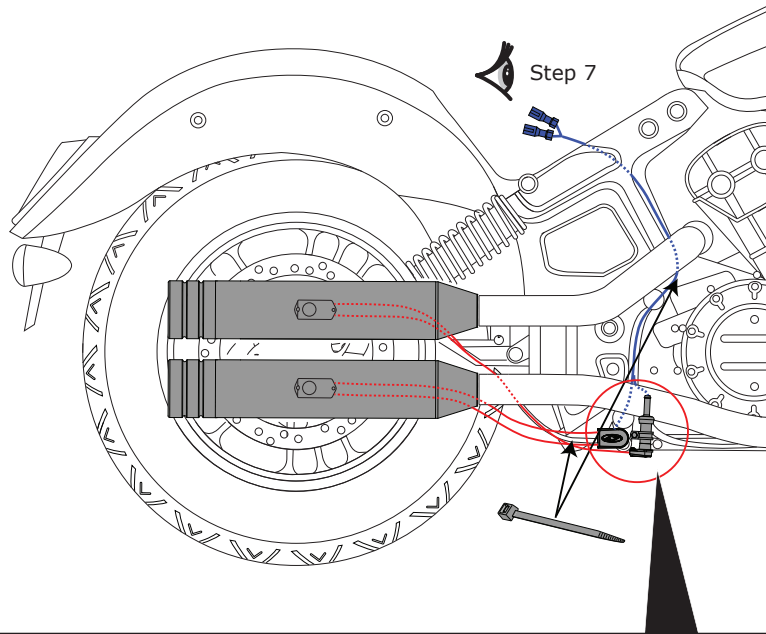
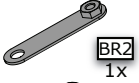
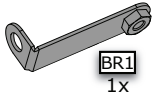

7

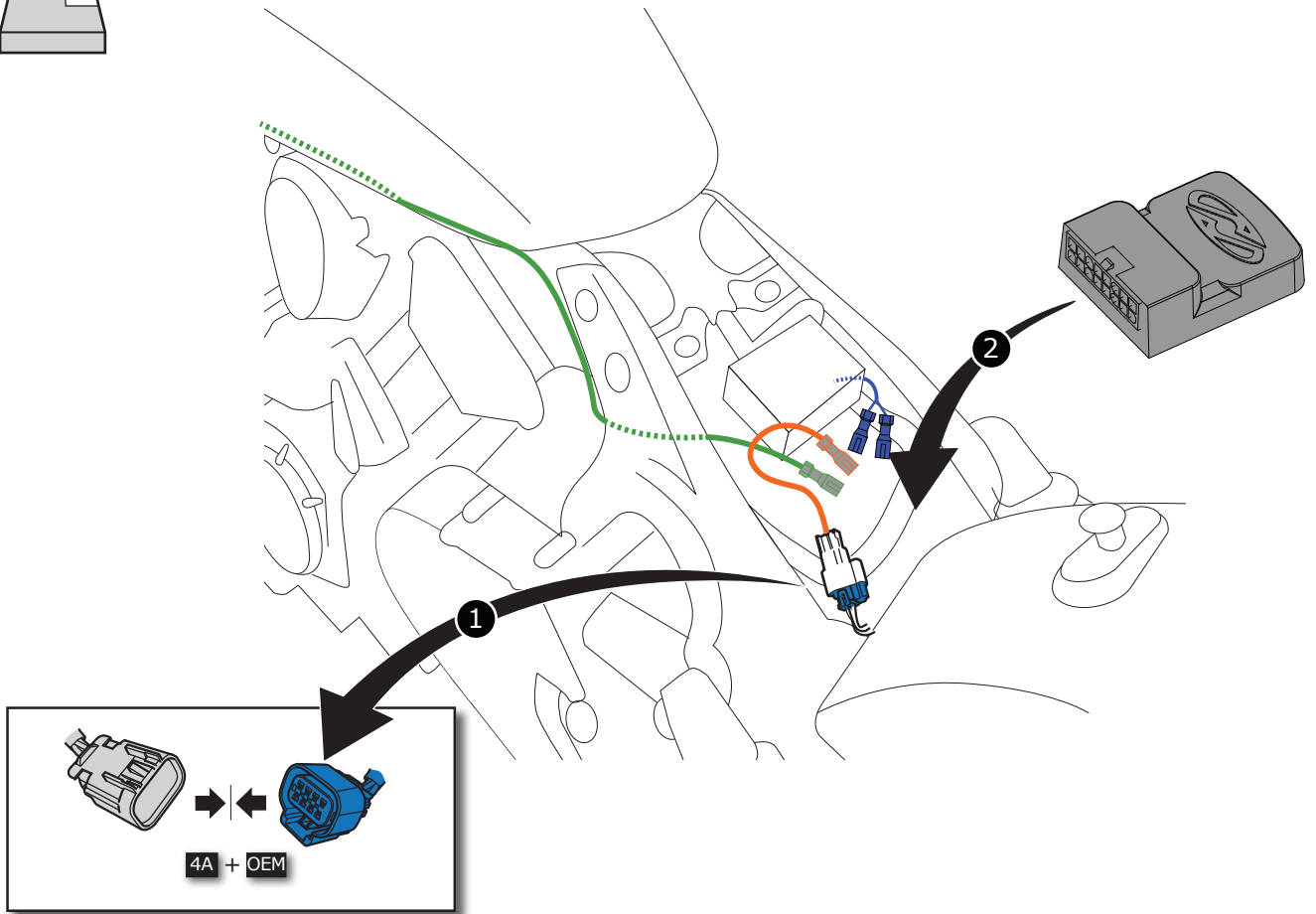
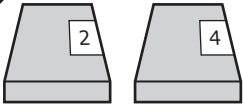

8

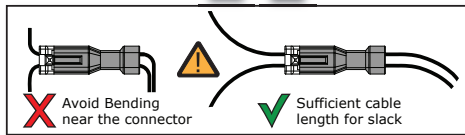
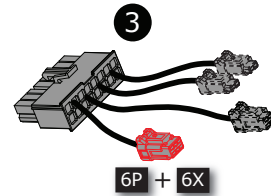
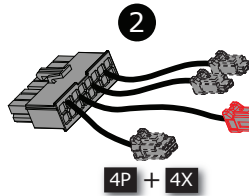
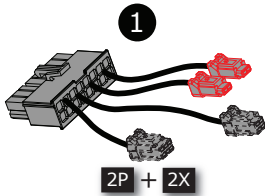
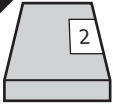

9

Complete System Check!

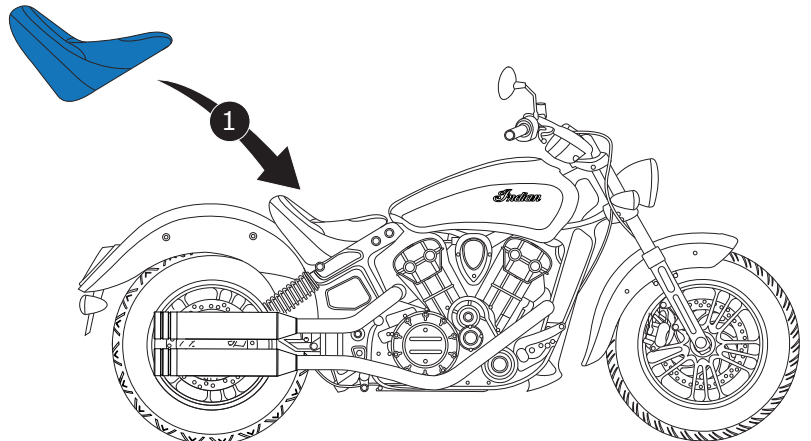
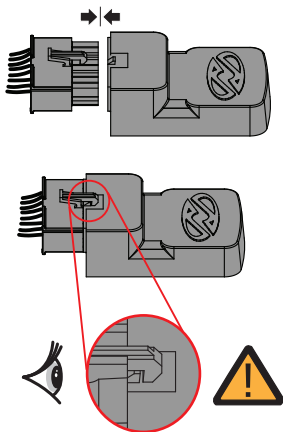



Dr. Jekyll & Mr. Hyde®
THE EXHAUST

DEALER INFO



Important notice

You need to break in the exhaust for the Indian Scout. After the first 100 km the sound of Mr. Hyde will be fully manifested. The sound is at his best when the exhaust and bike are at the right temperature.

Tip: when you let your customer hear the exhaust for the first time, make sure the bike is already warm to give them the best experience.



Wichtiger Hinweis

Der Auspuff für die Scout muss erst eingefahren werden. Erst nach den ersten 100 km wird der Sound von Mr. Hyde vollständig erreicht. Der Sound ist am besten, wenn der Auspuff und das Bike warm sind.

Tip: Wenn Ihr Kunde zum ersten Mal den Dr. Jekyll & Mr. Hyde Auspuff zu hören bekommt, vergewissern Sie sich, dass das Motorrad bereits warm ist, um das beste Sounderlebnis zu erhalten.



Belangrijke mededeling

De uitlaat dient eerst ingereden te worden. Na deze eerste 100 km zal het geluid van Mr. Hyde volledig tot uiting komen. De sound is op zijn best wanneer de uitlaat en de motor op temperatuur zijn.

Tip: wanneer u uw klant voor de eerste keer de uitlaat laat horen, zorg dan dat de motorfiets al warm is om hen de beste ervaring te geven.



Avis important

Vous devez roder l'échappement pour l'Indian Scout. Après ses premiers 100 km, le son de Mr. Hyde se manifestera pleinement. Le son est à son meilleur lorsque l'échappement et la moto sont en température.

Conseil: lorsque vous faites écouter à votre client l'échappement pour la première fois, assurez-vous que la moto soit déjà chaude pour offrir la meilleure expérience.

WWW.JEKILLANDHYDE.COM



Dr. Jekyll & Mr. Hyde®
THE EXHAUST

DEALER INFO



Important notice

You need to break in the exhaust for the Indian Scout. After the first 100 km the sound of Mr. Hyde will be fully manifested. The sound is at his best when the exhaust and bike are at the right temperature.

Tip: when you let your customer hear the exhaust for the first time, make sure the bike is already warm to give them the best experience.



Wichtiger Hinweis

Der Auspuff für die Scout muss erst eingefahren werden. Erst nach den ersten 100 km wird der Sound von Mr. Hyde vollständig erreicht. Der Sound ist am besten, wenn der Auspuff und das Bike warm sind.

Tip: Wenn Ihr Kunde zum ersten Mal den Dr. Jekyll & Mr. Hyde Auspuff zu hören bekommt, vergewissern Sie sich, dass das Motorrad bereits warm ist, um das beste Sounderlebnis zu erhalten.



Belangrijke mededeling

De uitlaat dient eerst ingereden te worden. Na deze eerste 100 km zal het geluid van Mr. Hyde volledig tot uiting komen. De sound is op zijn best wanneer de uitlaat en de motor op temperatuur zijn.

Tip: wanneer u uw klant voor de eerste keer de uitlaat laat horen, zorg dan dat de motorfiets al warm is om hen de beste ervaring te geven.



Avis important

Vous devez roder l'échappement pour l'Indian Scout. Après ses premiers 100 km, le son de Mr. Hyde se manifesterá pleinement. Le son est à son meilleur lorsque l'échappement et la moto sont en température.

Conseil: lorsque vous faites écouter à votre client l'échappement pour la première fois, assurez-vous que la moto soit déjà chaude pour offrir la meilleure expérience.

WWW.JEKILLANDHYDE.COM