



SN. . . . .

# Dr. Jekyll & Mr. Hyde<sup>®</sup>

## THE EXHAUST

MANUAL : INDIAN<sup>®</sup> | EASYMOUNT | SMARTBOX 2

**NEW IN THIS MANUAL:  
- 2019 MODEL**



**FTR 1200 (S) Lower  
2019->**

**NOTE: FOR OPTIMAL SOUND AND PERFORMANCE THE ENGINE HAS TO BE WARM (APPROX 80°C)**

1

# FTR 1200 (S) Lower 2019->

## Easymount Smartbox 2

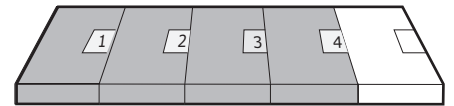

### 1 Assembly Kit

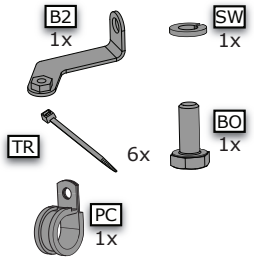

### 2 Smartbox 2

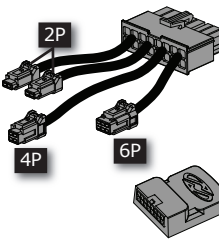

### 3 Mode Switch for Smartbox

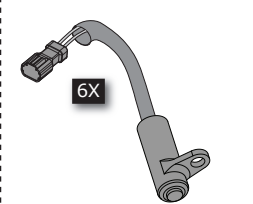

### 4 Smartbox Control Cable

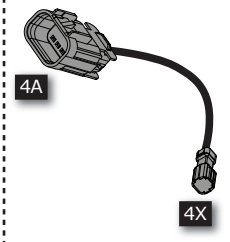

### 5 Bracket set

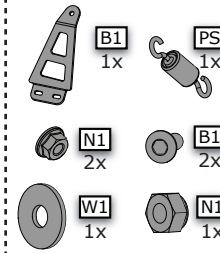

### Exhaust/Cable /Servo System

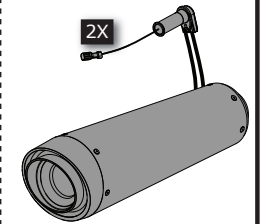

2

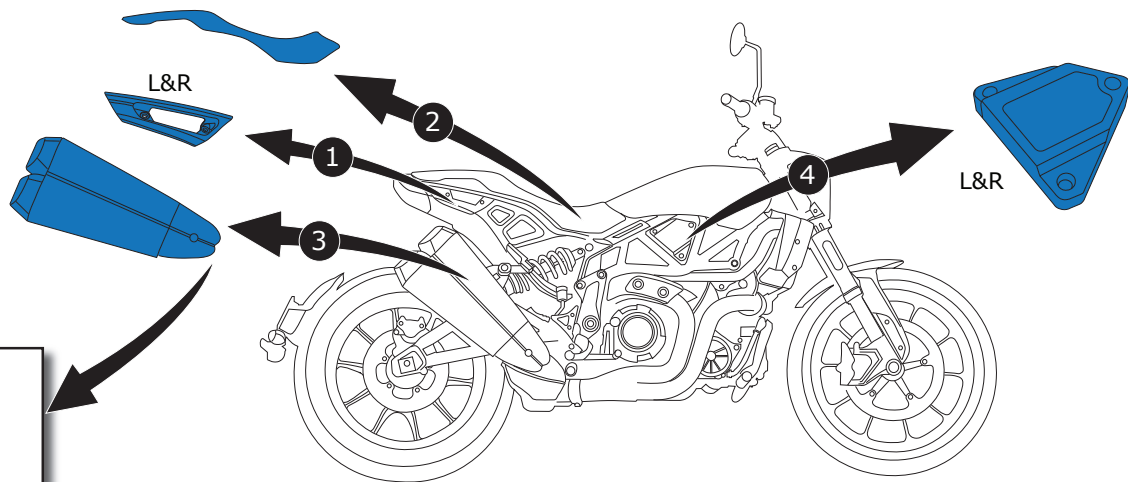

3

### Mount Link pipe & bracket to exhaust

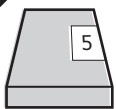
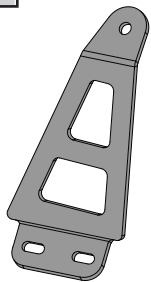
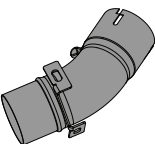
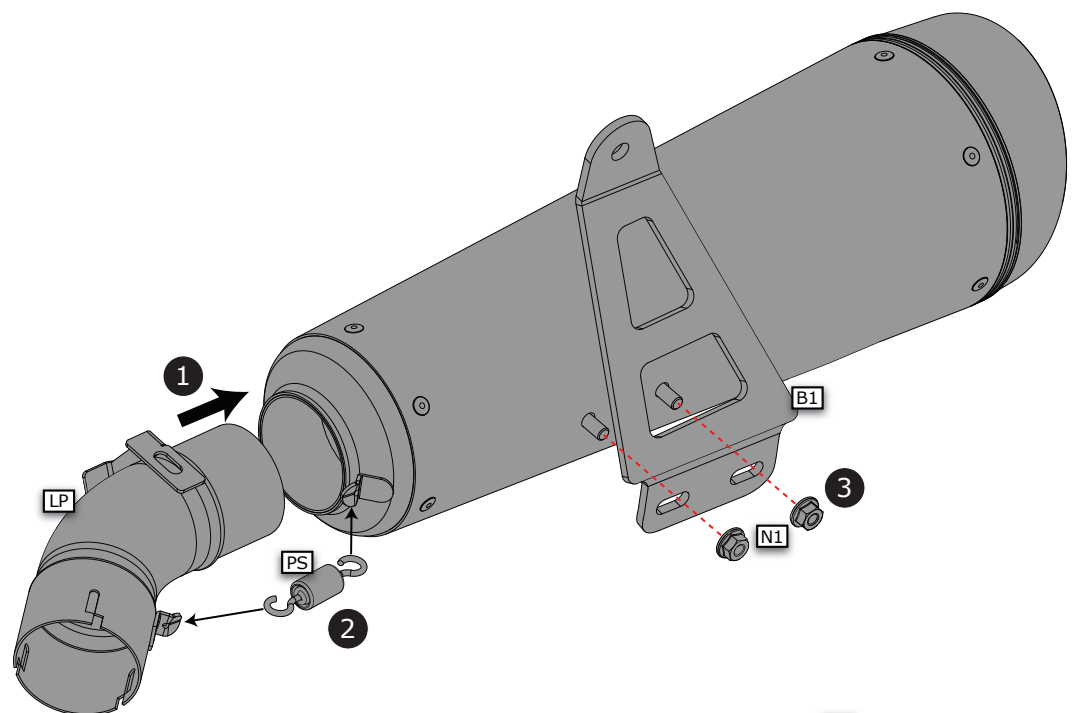
B1  
1xLP  
1xPS  
1xN1  
2xTighten **N1** at step 4

4

### Mount exhaust on motorcycle

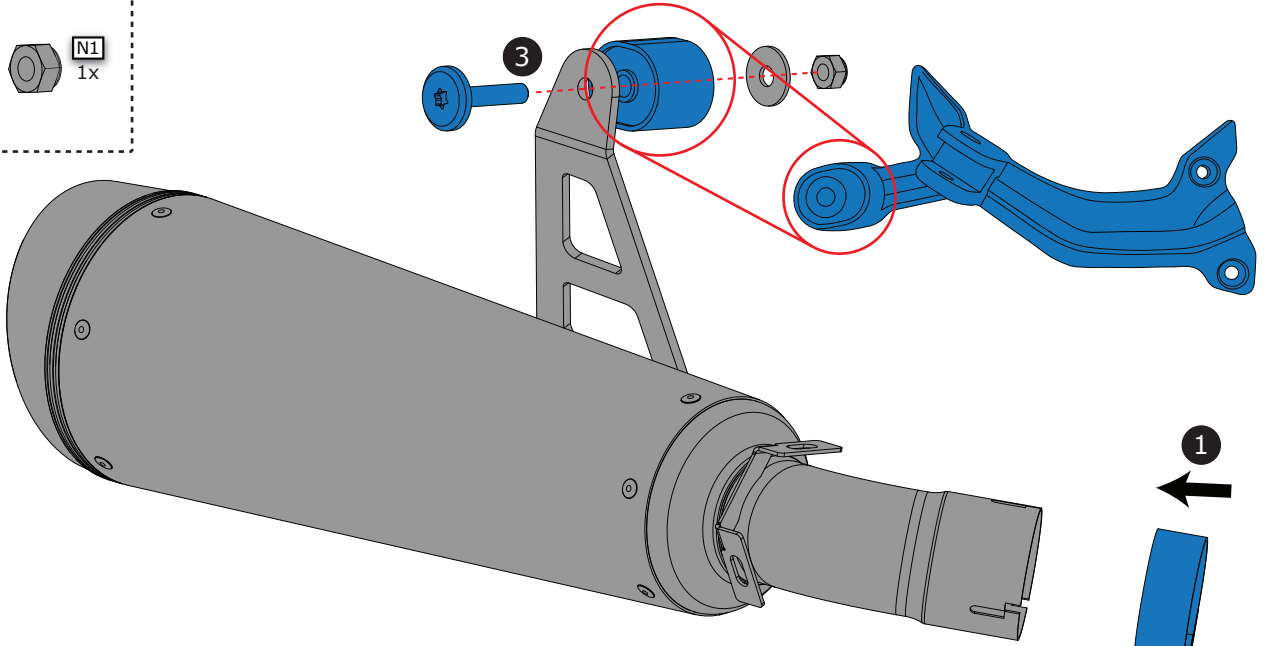
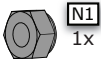
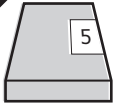

1

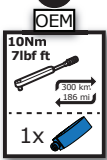

3



4



2 Attach exhaust to motorcycle header

5

### Items required

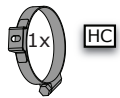
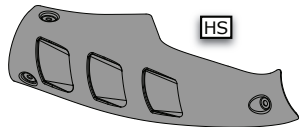

### Mount heat shield

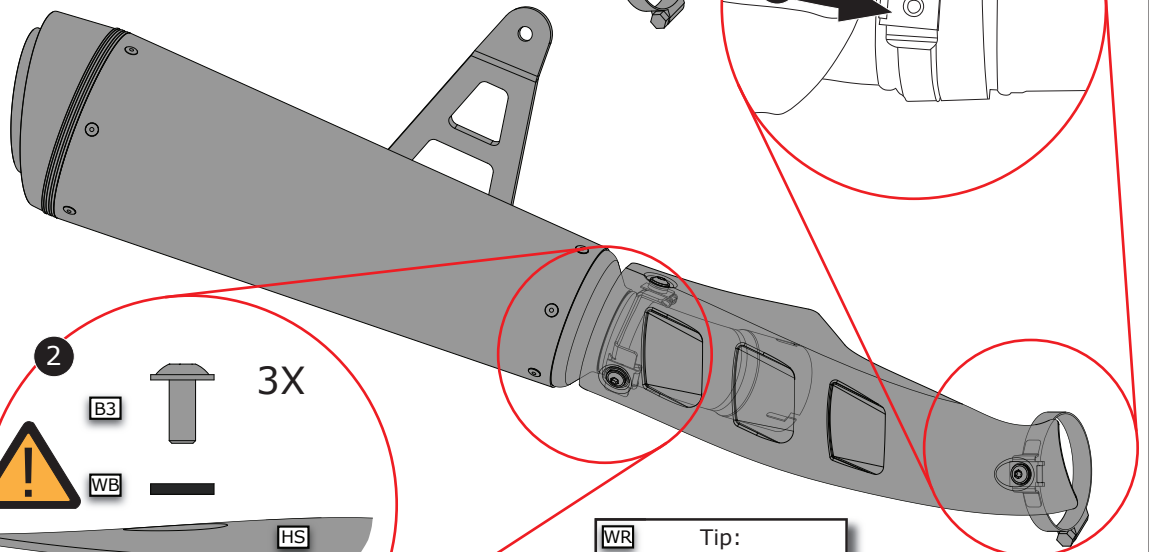

2

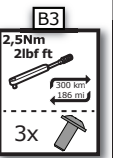
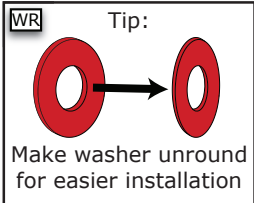
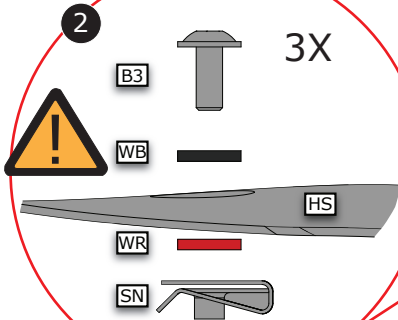

### Servo mounting & cable routing

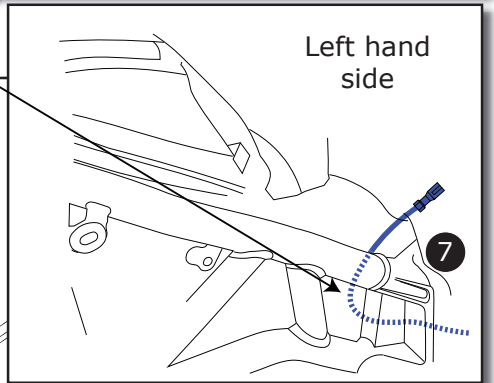
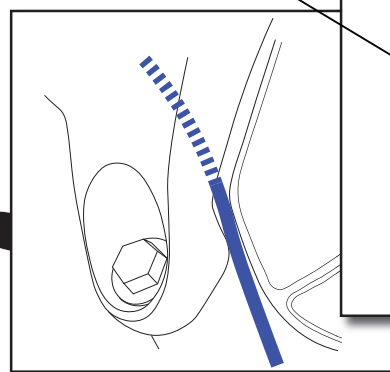
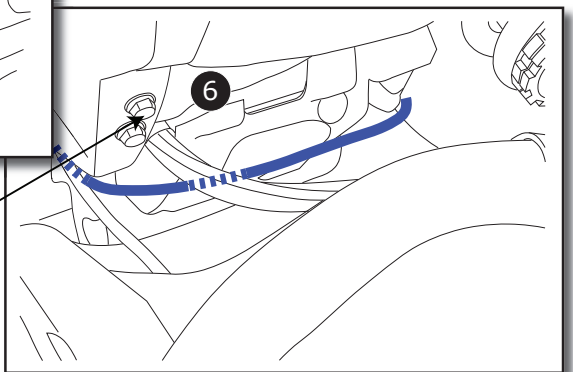
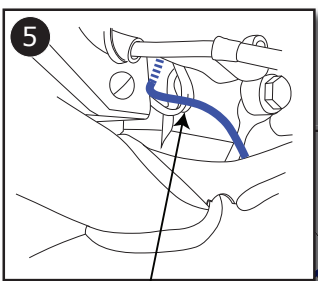
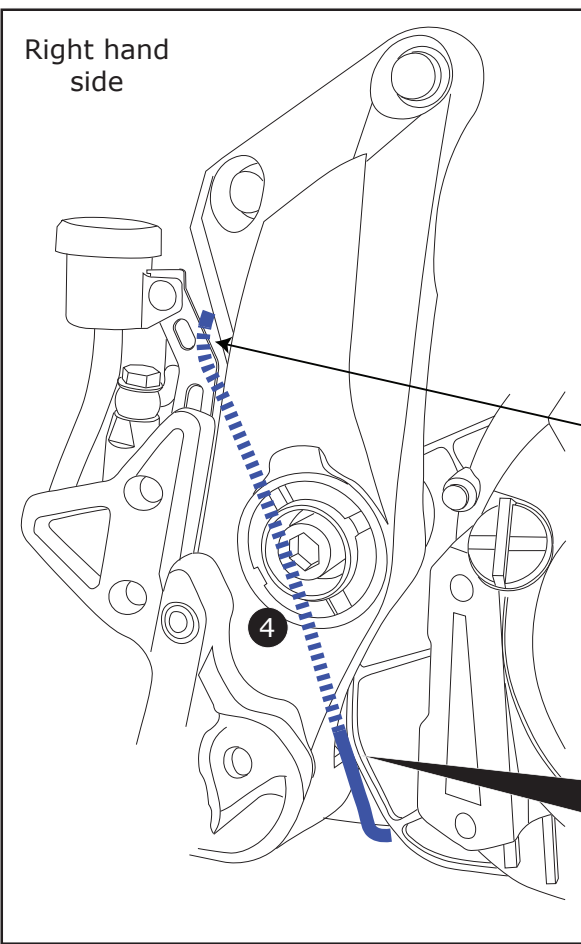
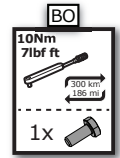
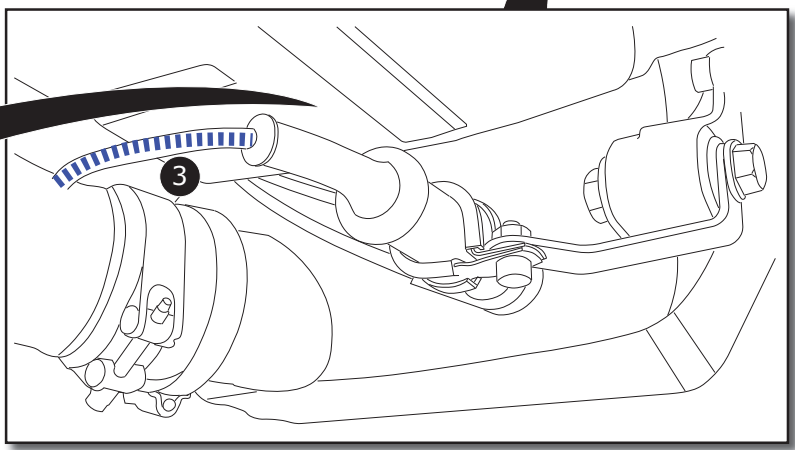
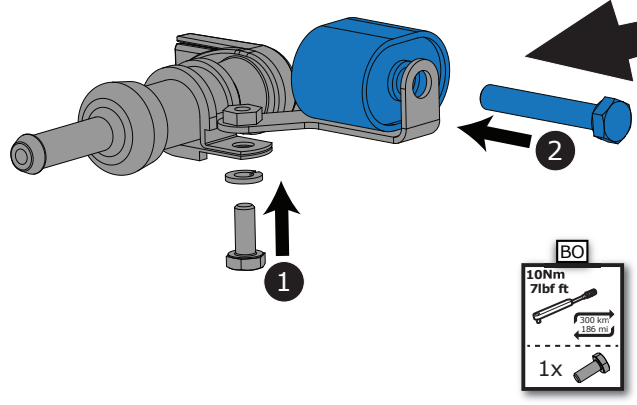
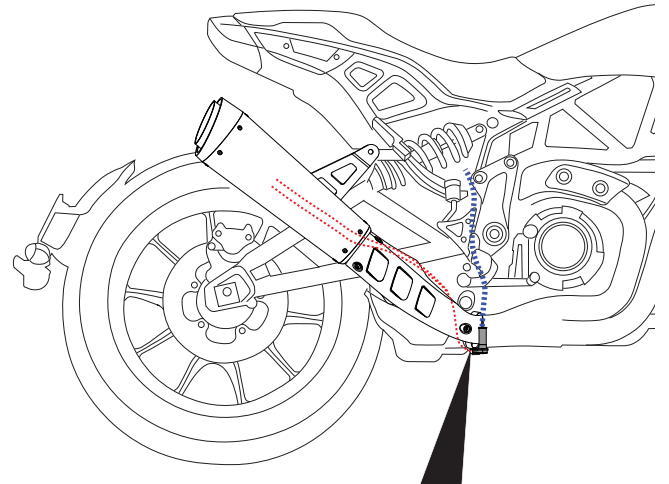
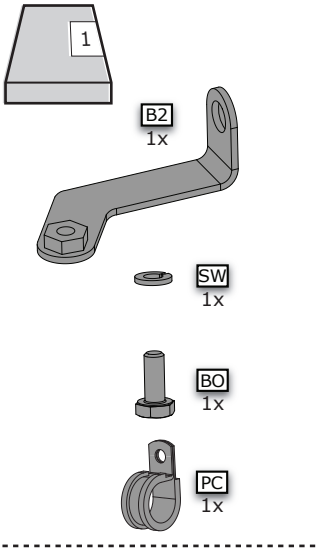

# Mode switch mounting & cable routing

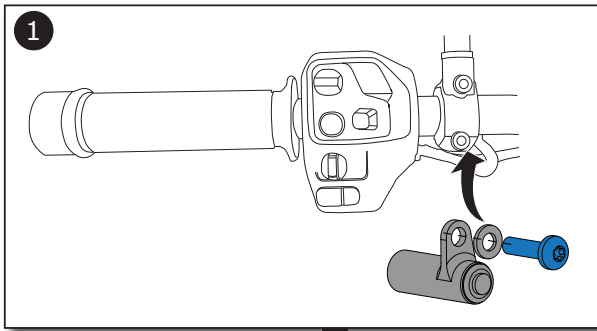
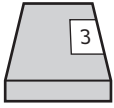

8Nm  
6lbf ft  
300 mm  
186 mm  
1x

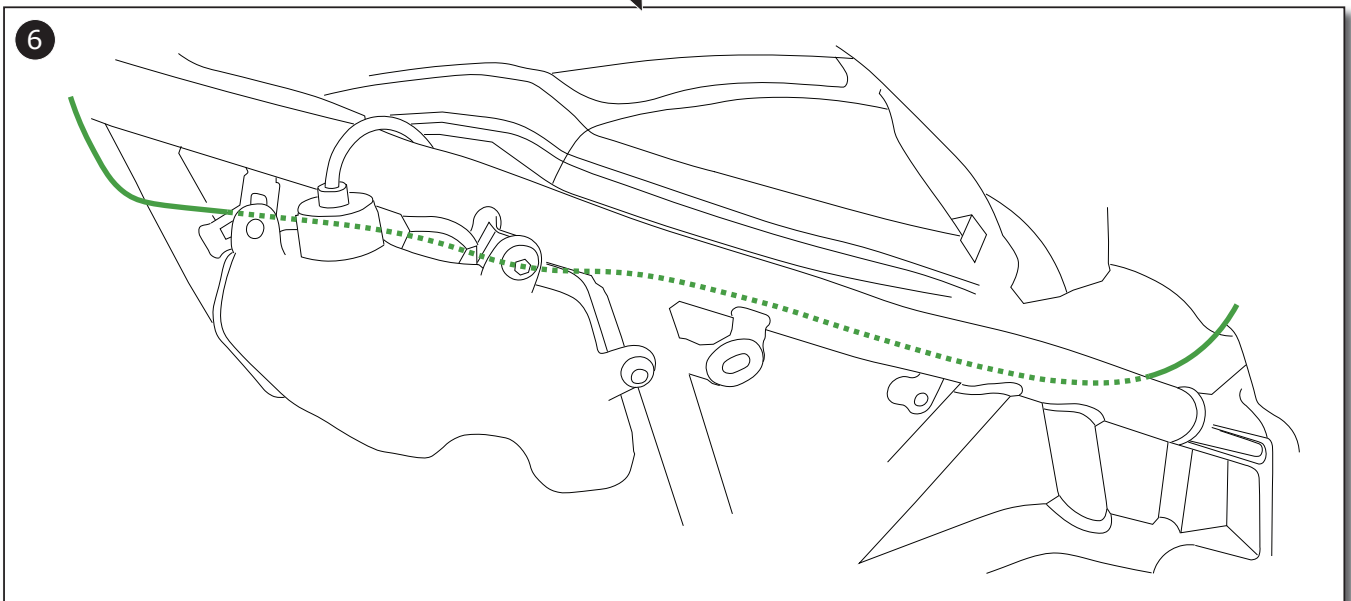
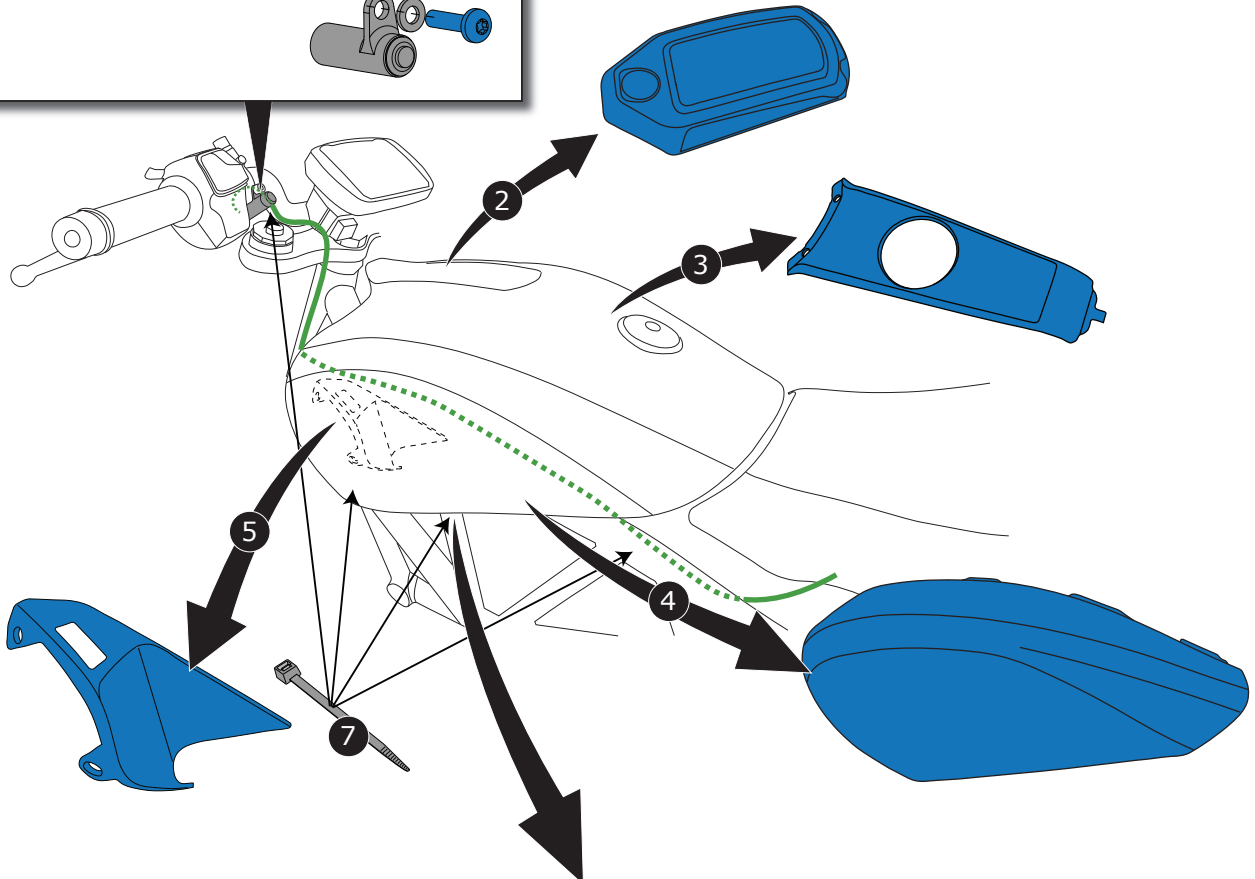

8

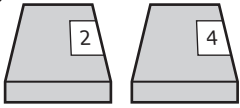

Place smartbox and smartbox control cable

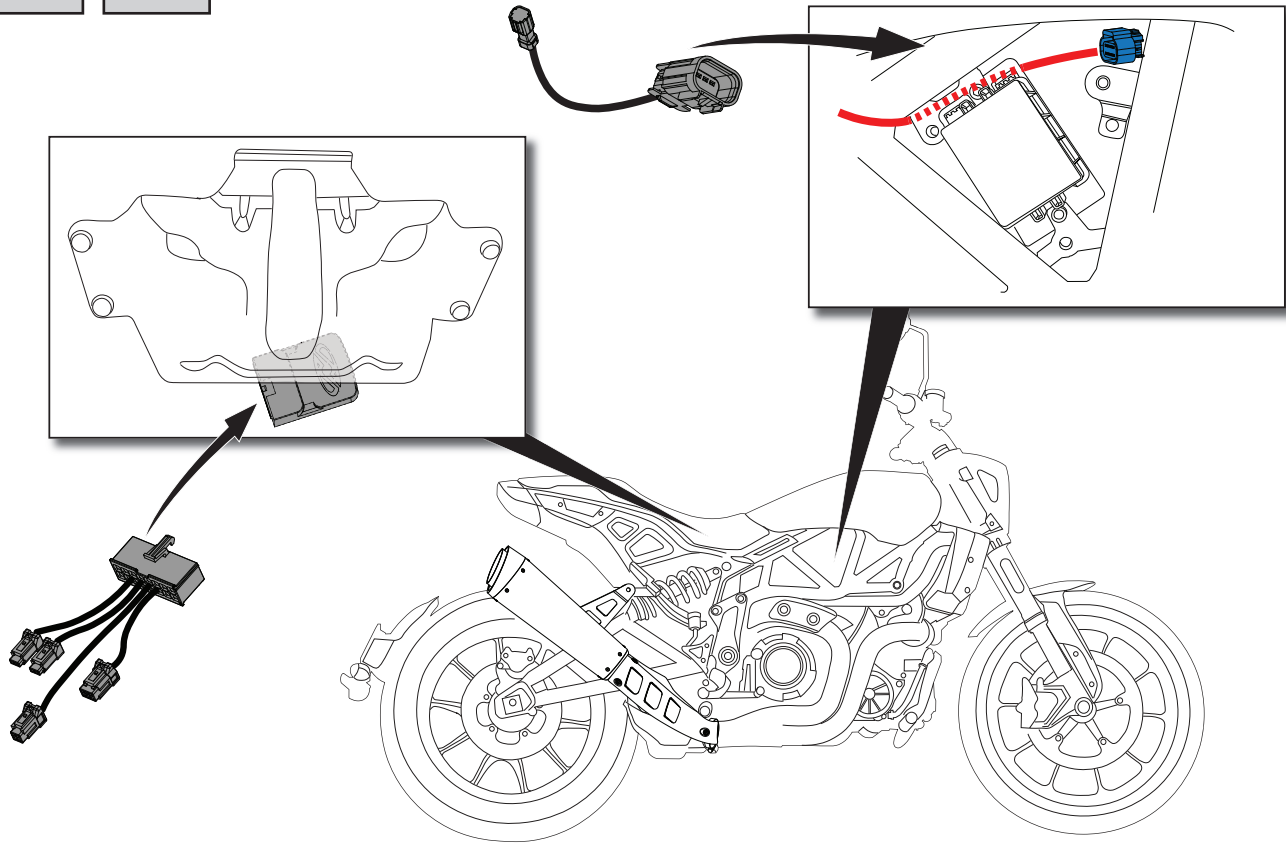

9

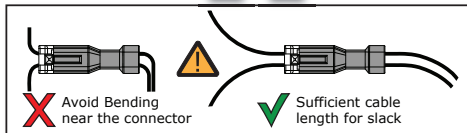
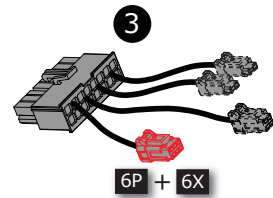
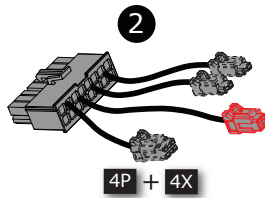
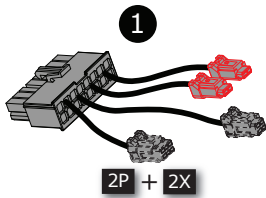

10

perform a Complete System Check!

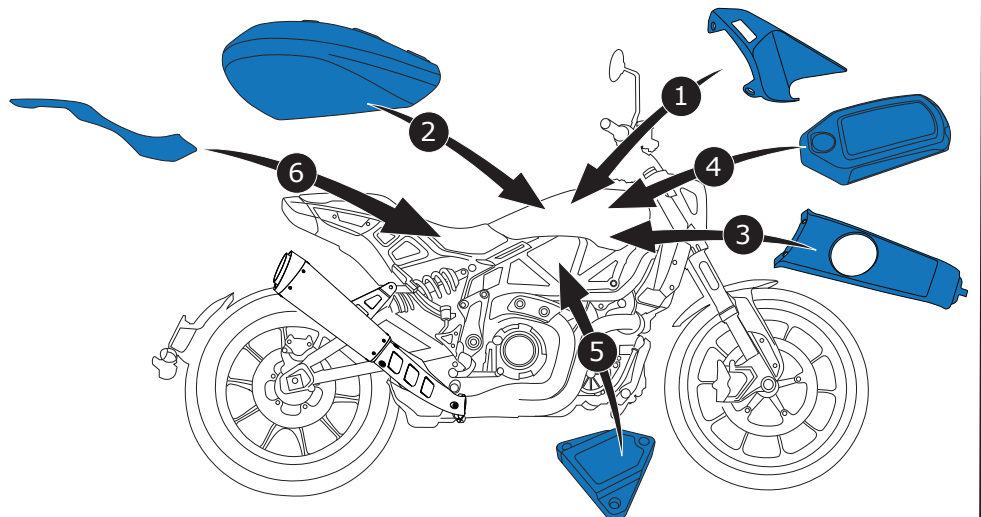



Dr. Tekill & Mr. Hyde®

## WAARSCHUWING



- In het geval van een uitlaat van titanium. Zorg voor een vetvrije ondergrond voordat u de motor start.
- Gebruik nooit een hogedrukreiniger, hot wax, olie (WD40) of cleaner met oplosmiddelen bv. benzine.

**DIT KAN BLIJVENDE VERKLEURINGEN /  
VLEKKEN VEROORZAKEN**



Schoonmaken **Chroom** systemen:

- Alleen reinigen wanneer de uitlaat afgekoeld is
- Eerst reinigen/afspoelen met water
- Gebruik poets die bestemd is voor chroom
- Gebruik een schone zachte doek
- Nooit mechanisch of met een harde borstel poetsen

Schoonmaken **Andere** systemen:

- Alleen reinigen wanneer de uitlaat afgekoeld is
- Eerst reinigen/afspoelen met warm water
- Gebruik een zachte, vochtige, pluisvrije doek
- Geen chemisch reinigingsmiddel gebruiken (wel zeep)
- Nooit mechanisch of met een harde borstel poetsen

Indien de uitlaat gebruikt wordt in alle weersomstandigheden, dient deze regelmatig gereinigd te worden.

Uitlaat direct reinigen na blootstelling aan strooizout. Vermijd contact met olie of benzine wanneer de uitlaat heet is.

## WARNING



- In case of a Titanium exhaust. Please ensure a grease free surface before starting the bike.
- Never use high pressure cleaner, hot wax, oil (WD40) or cleaner with solvents e.g. gasoline.

**THIS CAN CAUSE PERMANENT  
DISCOLORATION / STAINS**



Cleaning of **chrome** exhaust systems:

- Only clean when exhaust is cooled down
- Clean/rinse with water first
- Use a cleaner suitable for chrome
- Use a clean soft cloth
- Never use a mechanical or hard brush for cleaning

Cleaning of **other** exhaust systems:

- Only clean when exhaust is cooled down
- Clean/rinse with warm water first
- Only use a soft, damp, lint-free cloth for cleaning and removing remaining water
- Do not use chemical cleaning agents (only soap)
- Never use a mechanical or hard brush for cleaning

All weather riders are advised to regularly clean their exhaust system. It is necessary to clean the exhaust system immediately after exposure to de-icing salts. Please avoid contact with gasoline and oil when the system is heated.

## ACHTUNG



- Im Falle eines Titanauspuffs. Bitte achten Sie auf eine fettfreie Oberfläche, bevor Sie das Motorrad starten.
- Benutzen Sie zum Reinigen Ihrer Auspuffanlage keine Hochdruckreiniger, Heisswachs, Öle (bzw. WD40) oder Kaltreiniger bzw. Benzin.

**DIES KANN ZU BLEIBENDEN VERFÄRBUNGEN /  
FLECKEN IHRER AUSPUFFANLAGE FÜHREN**



Reinigung einer **chrome** Auspuffanlage:

- Nur reinigen wenn die Anlage komplett abgekühlt ist
- Die Anlage zuerst mit Wasser reinigen
- Ein Spezialreiniger für Chrome anwenden
- Ein sauberes, weiches Tuch benutzen
- Niemals eine mechanische oder harte Reinigungsbürste benutzen

Reinigung **andere** Auspuffanlage:

- Nur reinigen wenn die Anlage komplett abgekühlt ist
- Die Anlage zuerst mit warmem Wasser reinigen
- Ein sauberes, weiches Tuch benutzen
- Keine chemische Reinigungsmittel benutzen (nur Seife)
- Niemals eine mechanische oder harte Reinigungsbürste benutzen

Wind und Wetter Fahrer sollten Ihre Anlage grundsätzlich häufiger nach Vorschrift reinigen und Streusalze müssen immer direkt entfernt werden. Vermeiden Sie das die Anlage im heißen Zustand mit Ölen oder Benzin in Kontakt kommt.

# ATTENTION



- Dans le cas d'un échappement Titanium. Veuillez assurer une surface exempte de graisse avant de démarrer le moteur.
- Ne jamais utiliser un nettoyeur haute-pression, de la cire chaude (Hot Wax), de l'huile (par exemple WD40) ou du nettoyeur avec des solvants comme l'essence par exemple.



## CELA PUEDE CAUSAR DES TACHES ET DES DÉCOLORATIONS PERMANENTES.

Nettoyage du système d'échappement **chrome**:

- Nettoyer les échappements uniquement à froid
- Nettoyer / Rincer les échappements à l'eau
- Utilisez un nettoyeur pour le chrome
- Utilisez un chiffon doux et propre
- Ne jamais utiliser une brosse mécanique ou dur pour le nettoyage

Nettoyage de **autre** système d'échappement:

- Ne nettoyez l'échappement que lorsqu'il est froid
- Nettoyer / Rincer les échappements à l'eau chaude
- Utilisez uniquement un chiffon humide non pelucheux doux, pour nettoyer et enlever l'eau restante
- Ne pas utiliser de produits de nettoyage chimiques (seulement du savon)
- Ne jamais utiliser une brosse mécanique ou dur pour le nettoyage

Si on utilise les échappements dans toutes les conditions météorologiques, il faut les nettoyer régulièrement. Il est nécessaire de nettoyer l'échappement immédiatement après l'exposition au sel de voirie. Il faut éviter tout contact avec de l'huile ou de l'essence, si l'échappement est chaud.

# ATTENZIONE



- n caso di scarico in titanio. Accertarsi che la superficie sia priva di grasso prima di avviare il motore.
- Non utilizzare mai un sistema di pulizia ad alta pressione, cera calda, olio, lubrificanti (WD40), prodotti di pulizia con solventi, come benzine per esempio.



## QUESTO PUO' CAUSARE SCOLORIMENTI O MACCHIE PERMANENTI

Consigli per pulire scarichi in **cromo**:

- Attendere che la marmitta sia fredda
- Pulire/Bagnare prima con acqua
- Utilizzare un panno che non graffi il cromo
- Si raccomanda l'utilizzo di un panno di tessuto morbido
- Non utilizzare mai spazzole meccaniche o retine abrasive per pulire

Consigli per pulire **altro** scarichi:

- Attendere che la marmitta sia fredda
- Pulire/Bagnare prima con acqua calda
- Utilizzare un panno morbido umido, che non lasci fibre residue
- Non utilizzare agenti chimici per pulire (solo sapone)
- Non utilizzare mai spazzole meccaniche o retine abrasive per pulire

Appena lo scarico sarebbe utilizzato in tutte le condizioni atmosferiche, bisogna pulirlo regolarmente. E' necessario pulire immediatamente l'impianto di scarico dopo una esposizione a sale anti ghiaccio. Evitare il contatto con oli o benzine quando il sistema è caldo.

# ATENCIÓN



- En caso de escape de titanio. Asegúrese de tener una superficie libre de grasa antes de comenzar la motora.
- No utilice nunca una limpiadora de alta presión, cera caliente aceite (WD40) o disolventes (como por ejemplo la bencina).



## ESTO PUEDE CAUSAR DESCOLORACIONES O MANCHAS PERMANENTES

Sistemas de **cromo** limpias:

- Limpie solamente el escape cuando se haya refrescado
- Primero limpia/enjuague con agua
- Utilice un producto de limpieza adecuado para cromado
- Utilice un paño suave y limpio

La limpieza de **otros** sistemas

- Limpie solamente el escape cuando se haya refrescado
- Primero limpia/enjuague con agua tibia
- Utilice un paño húmedo y suave que no desprenda pelusa para quitar el agua que queda
- No utilice productos químicos para limpiar (solo jabón)

Cuando se utiliza el escape en todas las condiciones atmosféricas, hay que limpiarlo regularmente. Después de la exposición a sal (contra la nieve), limpie el escape en seguida. Evite todo contacto con aceite cuando el escape todavía está caliente.